

BVM SINGLE JOINT ELEVATOR

BVM Type "S" Single Joint Center Latch Elevators are available for handling casing and tubing sizes from 2-3/8" to 36" and 18° drill pipe sizes 2-3/8" to 6-5/8" and rated to 5 or 7.5 tons. An aluminum bushing style is available for tubing and casing sizes 1.050" to 6" and 18° drill pipe sizes 2-3/8" to 5-7/8" and is rated to 1 ton. This elevator has a safety pin to lock the latch. BVM elevators are made from certified alloy steel, heat treated magnetic particle inspected, and is manufactured and load tested per API 8C.

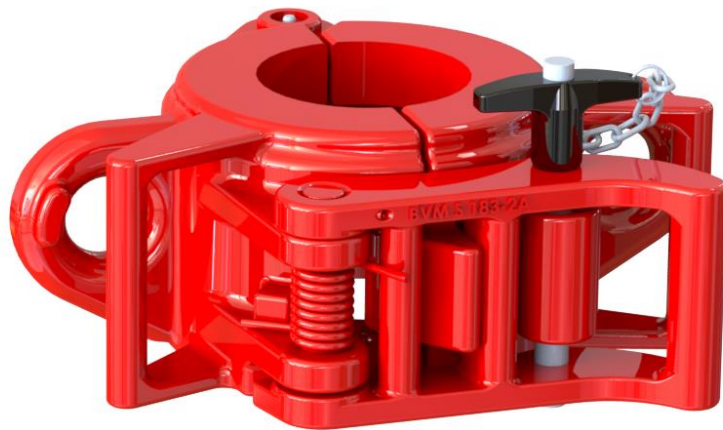
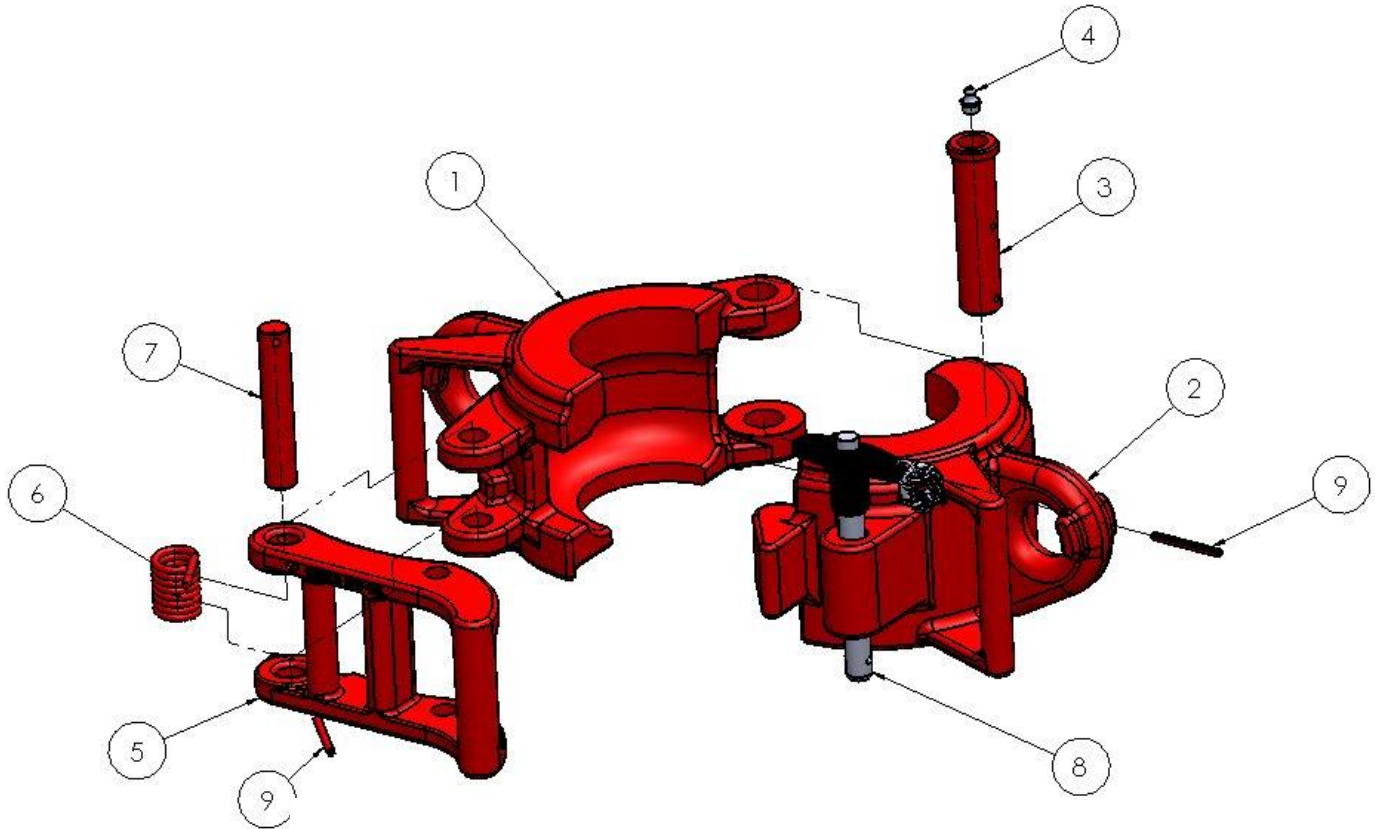

BVM CORPORATION

307 MAGNOLIA BUSINESS PARK DR.
MAGNOLIA, TX 77354; PHONE: 346-296-5501
www.bvmcorp.com; sales@bvmcorp.com

BVM SINGLE JOINT ELEVATOR

TUBING & CASING			
SIZE	5 TON P/N	7.5 TON P/N	WT (LBS)
2 3/8 NU	183-158	283-158	51
2 3/8 EU	183-159	283-159	51
2 7/8 NU	183-160	283-160	51
2 7/8 EU	183-161	283-161	51
3 1/2 NU	183-162	283-162	51
3 1/2 EU	183-163	283-163	51
4 NU	183-164	283-164	51
4 EU	183-165	283-165	51
4 1/2 NU	183-166	283-166	51
4 1/2 EU	183-167	283-167	50
4 3/4	183-130	283-130	50
5	183-131	283-131	50
5 1/2	183-132	283-132	50
5 3/4	184-133	284-133	50
6	184-134	284-134	65
6 5/8	184-135	284-135	65
7	184-136	284-136	65
7 5/8	184-137	284-137	65
8 5/8	185-139	285-139	85
9	185-140	285-140	85
9 5/8	185-141	285-141	85
9 7/8	185-649	285-649	85
10 3/4	186-142	286-142	115
11 3/4	186-143	286-143	115
13 3/8	186-144	286-144	115
14	186-690	286-690	115
16	187-145	287-145	170
18 5/8	187-146	287-146	170
20	187-147	287-147	170
21 1/2	188-148	288-148	283
24 1/2	188-149	288-149	283
30	189-644	289-644	412
Bushing	184B		58

18° DRILL PIPE	
API SIZE	ELEVATOR P/N
2 3/8 EU	283-116
2 7/8 IU	283-117
2 7/8 EU	283-118
3 1/2 IU	283-119
3 1/2 EU	283-120
4 IU	283-121
4 EU & 4 1/2 IU	283-122
4 1/2 EU & 5 IEU	283-123
5 1/2 EU (FH)	284-124
5 1/2 IF	284-678
5 7/8 IEU	284-789
6 5/8 IEU	284-740

CONTACT US FOR OTHER SIZES NOT LISTED.

ITEM NO.	P/N	DESCRIPTION	WEIGHT (LBS)
1	LEFT*	LEFT BODY	VAR.
2	RIGHT*	RIGHT BODY	VAR.
3	S-183-1A	HINGE PIN FOR S183-S184 / S283-S284	1.0
	S-183-1B	HINGE PIN FOR S185-S188 / S285-S288	1.5
4	940308-1	GREASE FITTING	0.1
5	S-183-2A	LATCH FOR S183-S186 / S283-S286	1.7
	S-183-2B	LATCH FOR S187-S189 / S287-S289	2.0
6	S-183-3	LATCH SPRING	0.1
7	S-183-4	LATCH PIN	0.5
8	S-183-5B	SAFETY PIN ASSEMBLY WITH CHAIN	0.4
8.1	S-183-5-1	CHAIN	-
8.2	S-183-5-2	QUICK RELEASE PIN	-
9	40030-16-0	ROLL PIN (Qty: 2)	-
10**	1006C-08-0	3/8" FLAT HEAD BOLT (Qty: 6)	0.1
--	S-190B-XXX^	BUSHING	VAR.
--	S-183-6	SWIVEL SUSPENSION ASY. W/ SHACKLE	29.0
--	S-183-7	SWIVEL SUSPENSION ASY.	25.0

*The Left and Right Body P/N depends on the size of the elevator

**Only for bushing type elevator 184B

^XXX Depends on bore size; Available in tubing/casing sizes 1.050" - 6" & 18° 2-3/8" - 5-7/8"

8/13/2023