

BVM Corporation Maintenance Manual

SERIES "G" ELEVATOR

100, 150, 175, 250, 350 & 500 Tons

Part number: _____

Serial Number: _____



Safety

CAUTION: Practice safety in the operation and maintenance and use only approved safety methods, materials and tools. Keep hands away from any pinch point or undesignated areas; use only the provided handles for operating the elevator.

WARNING: Elevators which have experienced wear beyond established wear criteria set by OEM, or are found to have cracks must be replaced or repaired by a BVM authorized repair facility.

WARNING: Only original BVM parts may be used. Elevators are produced from cast alloy heat treated steel and must not be welded in the field. Improper welding can cause cracks and brittleness in heat-affected areas which can result in dramatic weakening of the part and possible failure. Repairs involving welding and/or machining should be performed only by a BVM authorized repair facility. Using an Elevator that has been improperly welded or repaired is dangerous.

NOTE: The owner and user together with the manufacturer should jointly develop and update inspection, maintenance, repair and remanufacture procedures consistent with equipment application, loading, work environment, usage and other operational conditions. These factors may change from time to time as a result of new technology, equipment history, product improvements, new maintenance techniques and changes in service conditions. Alternatively, BVM recommends using the Periodic inspection and maintenance Categories and Frequencies as mentioned in API RP8B Table 1.

Load test

WARNING: BVM elevators are load tested after manufacture or repair. Load testing is mandatory on elevators which have not been load tested before. Load testing is required on elevators which have been overloaded, for example jarring operations or operations

that have induced elevators to high accelerations or high impact loads. In addition, after the load test, an annual inspection should be performed.

Confidentiality Statement

This document contains proprietary and confidential information, which is the property of BVM Corporation. No use or disclosure is to be made without the express written consent of BVM Corporation.

Note: Original Instructions are published in English; in the event the end-user may wish to obtain a translation of these in the official language of the country in which the machinery is to be used please contact your local BVM representative or BVM directly. Please note that this service may not be free of charge. Original Instruction can be downloaded from www.bvmcorp.com

Contents

Safety	1
Purpose	2
Description.....	2
Operation	3
Maintenance.....	4
Lubrication.....	4
Inspection.....	5
Wear data	8
Critical Area Drawings	10
Troubleshooting.....	11
Risk Assessment According to EN-ISO 12100:2010.....	12
Recommended Spares for 1 year of Operation.....	13
Assembly drawing and List of Parts	13

Purpose

This manual contains operation and service instructions for Type G – MG 100 Ton, RG 150 Ton, MGG 175 Ton, MGG 250 Ton, GG 350 Ton, and HGG 500 Ton. This manual provides a guide for assembly, disassembly, inspection, and repair.

Description

The BVM “G” Series type center latch taper elevators are used for handling 18° external upset drill pipe. The BVM elevator comes in sizes ranging from 2-3/8” through 6-5/8”, with a capacity of 100, 150, 175, 250, 350 & 500 tons. Elevators are made from alloy steel; load tested and are magnetic particle inspected.

CE Marking (if applicable):



Operation

The latch and safety latch lock of the G elevators lock automatically when the elevator is closed around the pipe by using the front handles. To open the elevator, simply pull the latch lock handle out and swing the elevator halves apart. Proper inspection, operation, and assembly are key to prevent dropped objects.

Installation:

- 1) Remove cotter pin and nut from link block bolt and remove link block bolt.
- 2) Lift the bottom of the link block and hook the small end to the link through the link block and link arm.
- 3) Lower the link block and re-install the link block bolt, nut and cotter pin.
- 4) Repeat this procedure on the other link block.
- 5) To remove, simply reverse the installation process.

Warning:

- Elevators are manufactured to operate only in a vertical direction (within 15°) and should NEVER be used for laying down on the ground for picking up pipe or tubing.
- The load rating of the elevator should never be exceeded. Both the static and dynamic loads must be calculated to ensure safe working loads.
- Be sure to use the handles provided for opening and closing the elevator. Keep hands away from all other areas when the elevator is in use.
- Check the latch and latch lock for full engagement when closed around the pipe.
- Make sure the G elevators are used with the correct size, tubing or pipe (per specifications). Oversized pipe could result in the elevator latching partially or not at all. Undersized or oversized pipe could cause uneven stress distribution. Inadequate load-bearing area, and possible elevator failure.
- Elevators are made from cast alloy steel and should not be welded in the field. Improper welding can cause cracks and brittleness in repaired area and can result in drastic weakening of the Elevator and Parts and possible Failure.
- Repairs which involve welding and or machining by others that is not authorized by BVM will void the warranty.
- Using an Elevator which has been improperly welded can result in serious bodily harm and property damage.
- Never use the elevator other than what it is intended for: size and tonnage, which is clearly marked on elevator.
- Use the ears for lifting the elevator, not the handles.
- Only use the elevator within the specified temperature rating, which is -4°F to 150°F unless otherwise specified.

Note: If an elevator is used despite the above warnings BVM voids all warranties.

Maintenance

Safety should be practiced at all times when servicing the equipment always use BVM Corporation, approved safety methods, material and tools. Always wear protective gear for eyes, head and hands.

1. Check for worn hinge pin, latch pin, latch lock pin, and their mating parts. These may hinder proper opening and closing of door, latch and latch lock.
2. Check for proper operating of latch stop mechanism. Latch should not stop against the body when engaged.
3. Open elevator and check hinge pin for wear by checking the radial play between the body and door.
4. Check latch pin for wear by checking the radial play between the latch and body. Close elevator and check that the latch and latch lock mechanisms function properly. Open and close elevator several times, check for proper latch and latch lock function each time. Check for proper operation of latch stop mechanism.

Caution:

- Do not use any elevator if the Latch and Latch lock do not function properly.
- Use only parts manufactured and sold by BVM Corporation
- Re-machining of parts should be performed only at BVM Corporation. Improper machining could result in increased stress (Decreased Load carrying capability) or improper alignment of component parts. Either condition could be hazardous to personnel and equipment.
- Bodies and Doors should be matched by trained BVM personnel. For this reason, a body or door from one elevator should never be exchanged with a body or door from another elevator.
- Always wear gloves and eye protection when grinding, striking or handling parts.
- Do not use any elevator with wear in hinge pin, latch pin, and lock pin areas. Wear in these areas will cause latch and latch lock to function improperly and may cause failure.

Lubrication

Lubricate the Elevator regularly during usage and storage to prevent corrosion. Use an extreme pressure, multipurpose, lithium-based grease of No. 1 or No 2 consistency and multi-weight motor oil.

1. Lubricate on a regular basis when in use.
2. Oil or grease hinge, latch and latch lock pin
3. Grease hinge and latch pin through grease nipples.
4. Grease underside of link arms.
5. Grease springs.
6. Grease link retainer fasteners.
7. Lubricate regularly during usage and storage to prevent corrosion from attacking any part of the elevators operating mechanism.

Inspection (PER API-RP8B)

Daily Inspection (Cat. II – elevator in use)

1. Check for any worn and damaged parts.
2. Check for loose and missing parts.
3. Check condition of the latch spring and the latch lock spring.
4. Check for wear of the hinge pins for vertical play between latch, body and door
5. Open and close the elevator 5 times slowly and 5 times quickly. Check that the elevator works flawlessly without interference
6. Check state of lubrication
7. Check for any visible cracks
8. Check for any corrosion
9. Check good condition of all primary and secondary retention

Semi-annual inspection (Category III)

1. Try to open the latch by prying the latch between body and latch with a steel bar or screwdriver, the latch lock must prevent the latch from being opened (Figure 1a)
2. Open and close the elevator 5 times slowly and 5 times quickly. Check that the elevator works flawlessly without interference
3. Check that the latch is not forced outward when elevator body is wedged – top and bottom (Figure 1b).
4. Check that the lock hook has clearance on all sides around the lug pin (Figure 1c).
5. Check the clearance between latch and lug – top and bottom (Figure 2).
6. Check that the latch and Lug faces are parallel (Figure 2).
7. MPI the lifting ears.

Annual Inspection (Category IV)

1. Conduct Category III inspection.
2. MPI inspect the following parts (See critical areas drawings for cast parts):
 - Body
 - Door
 - Hinge Pin
 - Latch Pin
 - Latch

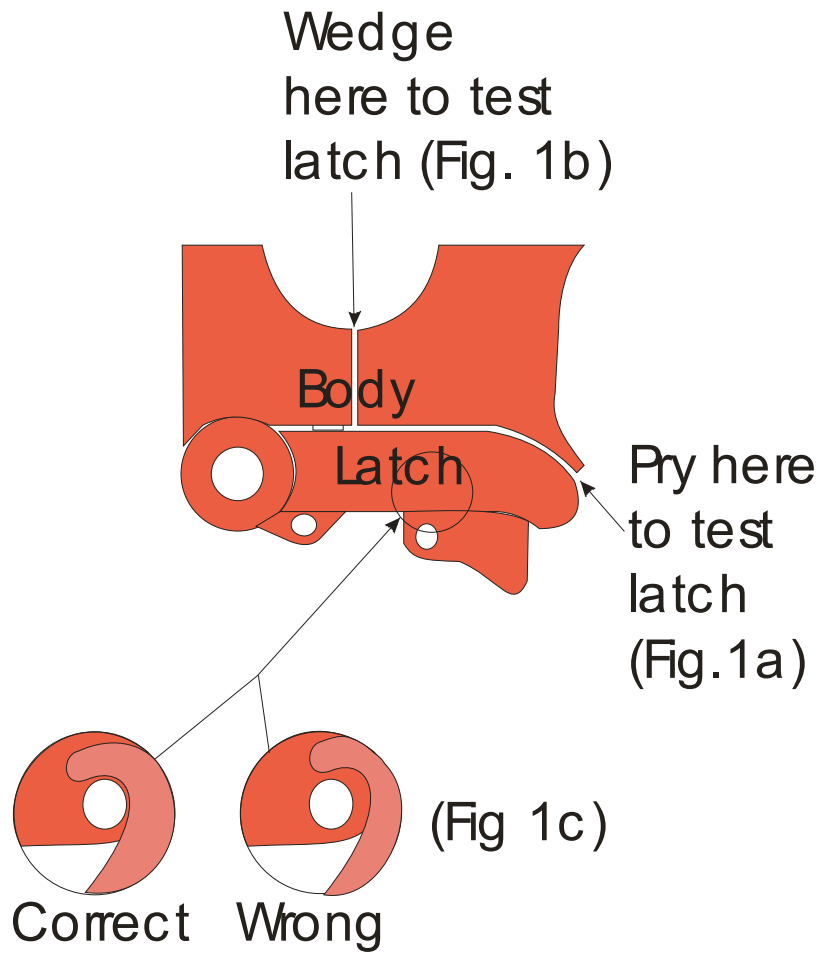

Figure 1: Latch wear inspection

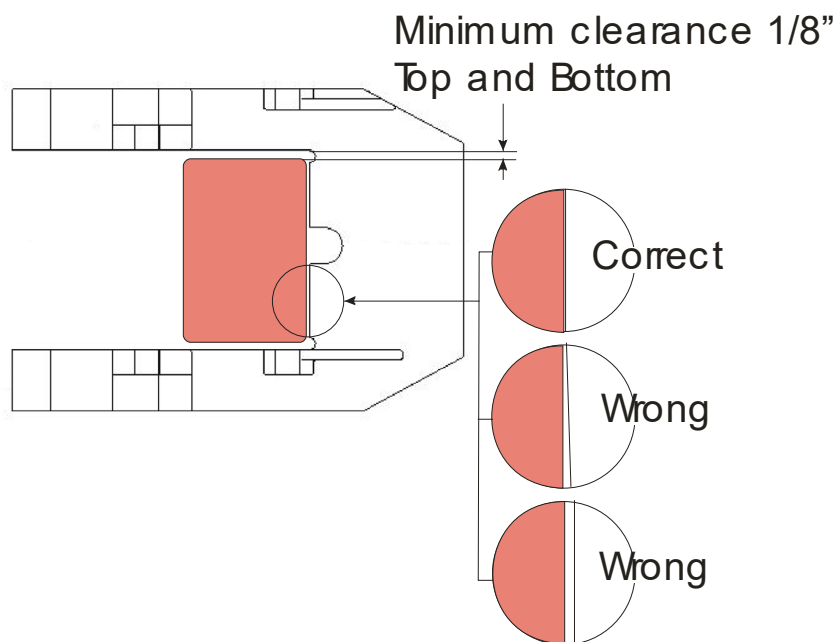

Figure 2: Latch wear inspection

Magnetic Particle Inspection (MPI)

Carry out MPI according to ASTM E709 or ASME BPVC sub section A, article 7 and subsection B, article 25; determine the type of defects and the degree by comparing defects to ASTM E125 reference photographs to the acceptance criteria.

Only cracks may develop and as such need to be reviewed. All other indication types have been addressed by the manufacturer during production. As such, the elevator has left the factory with indication (if at all) which were deemed acceptable. All cracks which have developed in service are relevant and need to be examined.

Evaluation of indications:

Relevant indications: Only those indications with major dimensions greater than 1/16 Inch (1.6mm) and associated with a surface rupture shall be considered relevant. Relevant indications are indications that results from, discontinuities within the test part. Non relevant indications are indications that results from excessive magnetizing current, structural design or permeability variances within the test parts. Any indication believed to be non-relevant shall be regarded as relevant and shall be re-examined to determine whether an actual defect exists. Linear indications shall be considered as those having a length of more than three times the width. Rounded indications shall be considered as those having a length less than three times the width. A lined indication shall be considered as a group of three more indications which touch an imaginary straight line connecting any two of the group.

For equipment certified in accordance with API 8A & 8C PSL 1:

Maximum Allowable Degree			
Type	Discontinuity Descriptions	Critical Areas	Non-critical Areas
I	Hot tears, cracks	None	Degree 1
II	Shrinkage	Degree 2	Degree 2
III	Inclusions	Degree 2	Degree 2
IV	Internal chills, chaplets	Degree 1	Degree 1
V	Porosity	Degree 1	Degree 2

For equipment certified in accordance with API 8A & 8C PSL 2:

Maximum Allowable Degree			
Type	Discontinuity Descriptions	Critical Areas	Non-critical Areas
I	Hot tears, cracks	None	None
II	Shrinkage	None	Degree 1
III	Inclusions	Degree 1	Degree 2
IV	Internal chills, chaplets	None	Degree 1
V	Porosity	Degree 1	Degree 2

Note: Only BVM authorized repair facilities are allowed to repair elevators with indications outside the acceptance criteria.

Wear data

The inspection data and maximum wear tolerances are only valid if the equipment is in otherwise good condition and has not been mis-used, does not exhibit excessive wear, cracks or other defects. Additionally, any weld repairs – not done at a BVM authorized repair facility – shall require examination and re-certification by a BVM authorized repair facility before being used further. These data and tolerances only apply to certain critical components and cannot on their own determine the overall condition of the equipment or its suitability for continued use. These data and tolerances are what is required to retain 100% ratings.

Caution: Remove from service any elevator with center bore taper less than 16°.

Table 1: Wear table

Elevator Type	MG	MG	RG	RG	MGG	MGG	GG	HGG
Rated Capacity (Ton)	100	100	150	150	175	250	350	500
Part Number	30157	30158	30156	30155	13884	35005	31068	70013
Size	2 3/8 - 4	4 - 5	2 3/8 - 3 1/2	4 - 5 1/2	2 3/8 - 5	2 3/8 - 5 1/2	3 1/2 - 5 1/2	3 1/2 - 6 5/8
Hinge Clearance (A)	0.030"	0.030"	0.030"	0.030"	0.030"	0.030"	0.035"	0.045"
Latch Clearance (B)	0.025"	0.025"	0.030"	0.030"	0.030"	0.030"	0.035"	0.035"
D (Min Worn)	3.25	3.5	3	3.75	4	4.75	4.25	5.75
R (Min Worn)	1	0.75	1.5	1.25	1.875	1.875	1.875	2
E (Nominal)	4.875	5.375	6.25	7	5.437	6.75	8	8.875

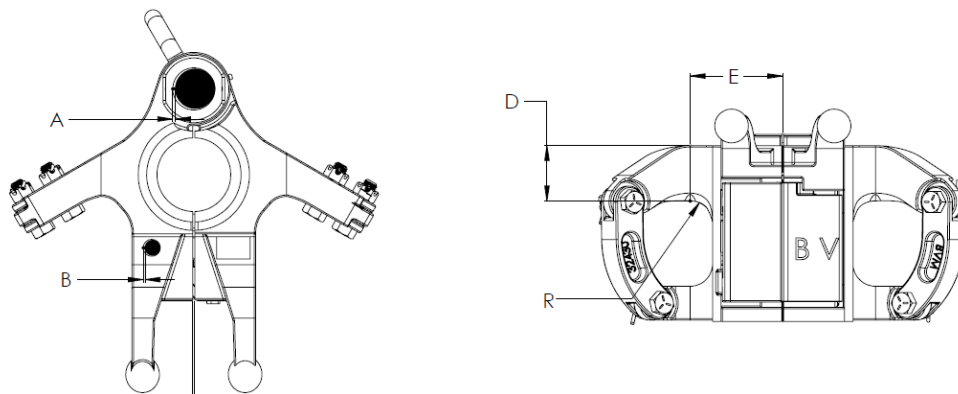

Figure 3: Wear variable

Bore size wear data

Procedure

1. Measure the center bore of the elevator ("C" Figure 4)
2. Determine the Nominal bore size
3. Maximum wear of center bore is Nominal size +0.25"

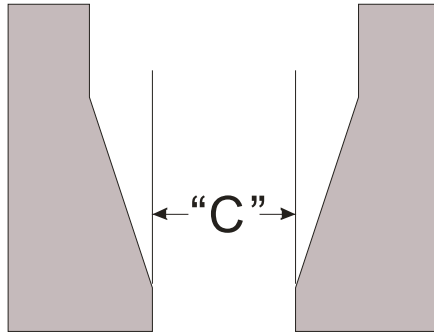

Figure 4: "G" Series center bore

Critical Area Drawings

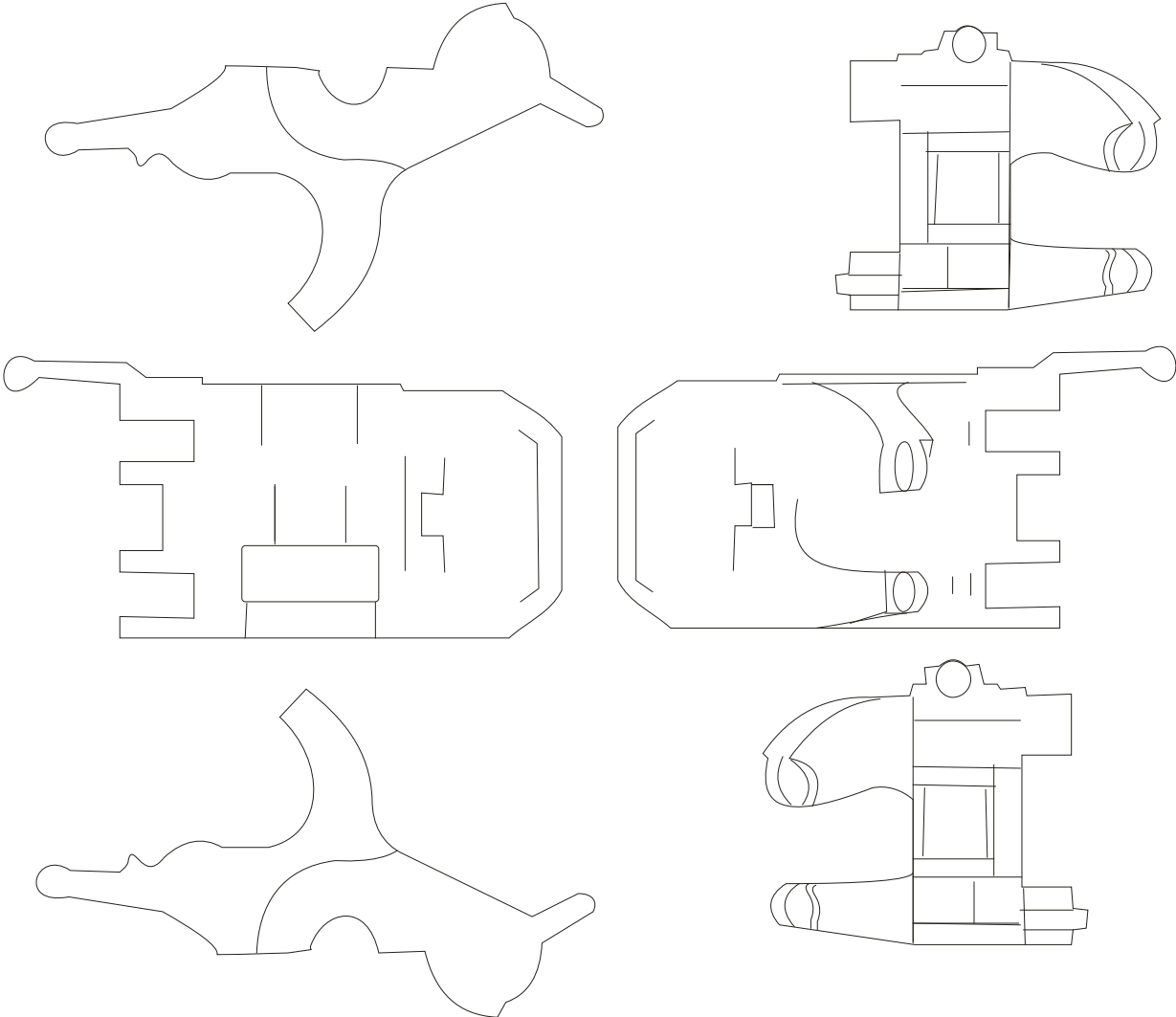

Figure 5: Body/Door critical area drawings

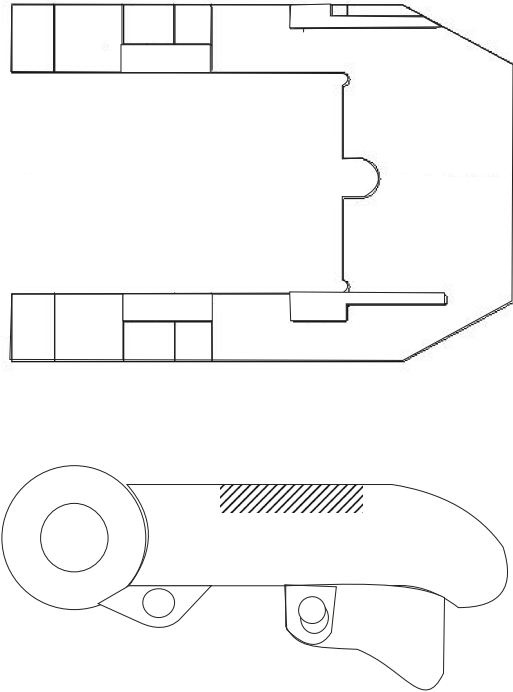

Figure 6: Latch critical area drawings

Troubleshooting

When problems cannot be solved, contact an authorized BVM repair facility.

Overview possible problems:

Problem	Possible cause	Possible solution
Elevator does not close or is difficult to close	Parts bent or damaged.	Check elevator.
	Pipe too big	Use different size elevator
Elevator does not hang level	Length of links not equal	Use same length slings
Elevator does not open	Yielding due to overload	Replace Elevator
	Elevator corroded	Open elevator by force, clean and lubricate. Check elevator for excessive wear.
Bent pins	Elevator was overloaded	Replace Elevator
Elongated holes	Elevator was overloaded	Replace Elevator
	Elevator holes worn	Check amount of wear. If within acceptance criteria use as is; when over acceptance criteria, replace Elevator

Risk Assessment According to EN-ISO 12100:2010

The conclusion of the risk assessment is that in general, the crew must:

- Wear person safety protection like safety glasses, hard hats, etc.
- Follow instructions as stated in the manual.
- Have knowledge of rig procedures.
- Must have been instructed for safe use of the tool.
- Always use secondary retention as established and implemented by BVM.
- Do not rely on visual signals “elevator closed and latched” from deckhand.

Applicable standards:

- EN-ISO 12100:2010 Safety of machinery – Basic concepts, general principles for design
– Risk assessment and risk reduction
- Machinery Directive: 2006/42/EC
- API 8C

Recommended Spares for 1 year of Operation

Rating	100	100	150	150	175	250	350	500	
Assembly PN	30157	30158	30156	30155	13884	35005	31068	70013	
Spare Part kit	30157-SP	30158-SP	30156-SP	30155-SP	13884-SP	35005-SP	31068-SP	70013-SP	
Component	Qty	Part Number							
Hinge pin	1	26813-2	26815	23569-1	23568	13888	34908	33998	30553
Latch	1	11763	11763	23543	200363	13151	34906	31071	30460M
Latch pin	2	26814	26814	23544-1	23567	13154	34907	33999	30613
Latch spring	1	11766	11766	23546	23546	13155	34909	18416-1	312281-
Latch spring stop	1	-	-	23548	23548	13185	13185	13185-1	31215
Latch cam	1	11581	11581	-	-	-	-	-	-
Latch lock	1	11764	11764	13152	13152	13152	13152	13152	13152-1
Latch lock pin	1	11759-1	11759-1	15101	15101	15101	15101	15101	31138
Latch lock bolt nut	1	-	-	6812C-00-5	6812C-00-5	6812C-00-5	6812C-00-5	6812C-00-5	6812C-00-5
Latch lock spring	2	-	-	13188	13188	13188	13188	13188	13188
Door lug pin	1	12529	12529	23547	23547	13190	13190	13190	31216
Hinge pin retainer	2	40040-28-0	40040-28-0	40040-24-0	40050-30-0	40050-16-0	40060-32-0	40060-40-0	51060-56-0
Latch pin retainer	2	40040-18-0	40040-18-0	40040-22-0	40040-22-0	40040-28-0	40040-28-0	40050-32-0	51060-36-0
Link block	2	26817	26817	9519	9519	9519	9519	9519	30942
Grease fitting	2	940308-1	940308-1	940308-1	940308-1	940308-1	940308-1	940308-1	940308-1

Assembly drawing and List of Parts

See data sheet at www.bvmcorp.com.